

# Sahara

## INDUSTRIAL OVENS

### Electric Hot Box Model E02

The Benko Products SAHARA HOT BOX drum heaters and ovens are recognized as the industry leader in 55-gallon drum and tote heating equipment. Electric drum heaters feature state-of-the-art digital controls with independent over-temperature protection. Low-watt density heaters assure years of trouble-free operation.



#### Specifications

The Hot Box has many unique features:

- Zero-ground clearance for pallet-jack loading / unloading
- Precise digital temperature control with overtemperature protection
- **3-year Manufacturer's warranty.**

#### Capacity

2 drums (55 gal.)

#### Materials of Construction

All steel construction includes:

- 12 gauge interior walls and 14 gauge exterior walls
- Integrated framing and structural members ensure toughness
- 304 stainless steel construction available

#### Dimensions

Interior dimensions:

59"W x 29"D x 60"H

Exterior dimensions:

66"W x 36"D x 79"H

#### Insulation

3" thick, 6# density mineral wool

#### Heating Medium

Electricity

#### Heat Capacity

- 6KW (optional kw ratings available)
- 240 or 480 volt, 3 phase (additional voltages available)
- Digital temperature controller with independent high temperature cut off

#### Temperature Range

Room temperature to 300°F

#### Finish

- Exterior finished with acrylic enamel
- Interior finished with heat resistant paint
- Stainless steel available

#### Weight

950 lbs.

#### Installation

Shipped completely assembled.  
Set in place and hook up power.

#### Air Circulation

330 cfm air circulation blower with controls; 1/3 HP, TEFC

\* Electric models not to be used to heat flammable or combustible materials.

\* Electric models are not explosion proof rated and should not be used in hazardous locations.

\* Class A ovens available for heating flammables.

Designed and  
Manufactured by:

**BENKO PRODUCTS**  
ENGINEERED TO BE MORE

Benko Products Inc. · 5350 Evergreen Pkwy · Sheffield Village, Ohio · 44054  
Phone (440) 934-2180 · Fax (440) 934-4052 · email: sales@benkoproducts.com  
[www.benkoproducts.com](http://www.benkoproducts.com)

## Electric Hot Box

### Model E02

SAHARA MODEL 6E02-CS

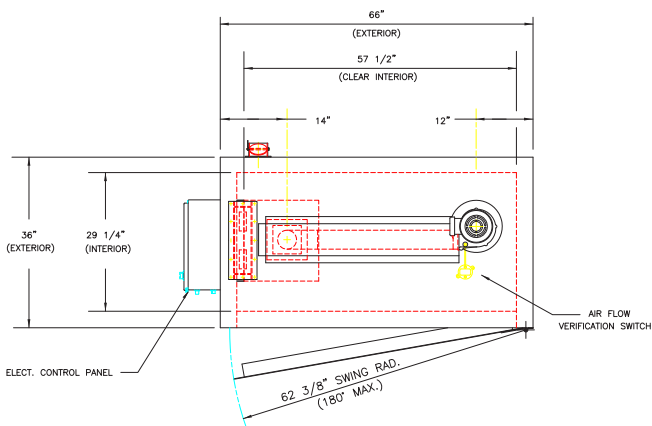

NOTES:

1. UNIT WEIGHT: 950 Lbs. (AS SHOWN)
2. FINISH:  
EXTERIOR: ACRYLIC ENAMEL  
INTERIOR: HEAT RESISTANT SILVER
3. HEATING MEDIUM:  
(2) 3 KW ELECTRIC HEATING ELEMENTS  
480V/3 $\phi$ /60HZ
4. SPILL CONTAINMENT: NONE
5. MATERIALS:  
EXTERIOR: HRS, 14 GA. (.075")  
INTERIOR: HRS, 12 GA. (.105")  
  
INSULATION: 3" X 6# DENSITY MINERAL WOOL  
(ALL WALLS, CEILING AND DOOR)
6. OPTIONS:  
330 CFM BLOWER (SHOWN)  
480V/.33 HP/3 $\phi$   
4" VENT WITH DAMPER  
PROGRAMMABLE TIMER  
CHART RECORDER

