



Manufactured by
BENKO PRODUCTS
ENGINEERED TO BE MORE

Steam Hot Box Model S4

The Benko Products SAHARA HOT BOX drum heaters and ovens are recognized as the industry leader in 55-gallon drum heating equipment. Steam drum heaters are available with state-of-the-art digital controls with independent over-temperature protection. Units in a manifolded arrangement can be individually turned off when not heating, perfect for your drum storage and drum heater needs.



Specifications

The Hot Box has many unique features:

- Rugged steel construction
- Portable; just pick-up with a forklift
- Built-in spill containment
- Zero-ground clearance available
- **2-year Manufacturer's warranty**

Capacity

4 drums (55 gal.) or 1 tote
4,000 lbs. total capacity

Materials of Construction

All steel construction includes:

- 12 gauge interior walls and 14 gauge exterior walls
- Integrated framing and structural members ensure toughness
- 304 stainless steel construction available

Dimensions

Interior dimensions:

59"W x 55.25"D x 47.5"H

Exterior dimensions:

66"W x 62"D x 66.75"H

Insulation

3" thick, 6# density mineral wool

Heating Medium

Steam, hot oil, or hot water

Heat Exchanger

Finned tube heating coil rated for saturated steam up to 200 psig. Recirculating coil available for hot oil or hot water.

Temperature Range

Room temperature to 350°F

Spill Containment Pan

55 gallon capacity

Finish

- Exterior finished with acrylic enamel
- Interior finished with heat resistant silver
- Stainless steel available

Unit Weight

2,050 lbs.

Installation

Shipped completely assembled.

Set in place and hook up power supply.

Engineering

Custom engineered, computer designed units are available. Contact us for more information.

* Class A ovens available for heating flammables.



Designed, Patented and
Manufactured by:

BENKO PRODUCTS
ENGINEERED TO BE MORE

Benko Products Inc. · 5350 Evergreen Pkwy · Sheffield Village, Ohio · 44054
Phone (440) 934-2180 · Fax (440) 934-4052 · email: info@benkoproducts.com
www.benkoproducts.com



Manufactured by
BENKO PRODUCTS
 ENGINEERED TO BE MORE

Steam Hot Box

Model S4

NOTES:

1. UNIT WEIGHT: 2050 Lbs.
2. FINISH:
 EXTERIOR: ACRYLIC ENAMEL
 INTERIOR: ALUMINUM-BASED ENAMEL
3. HEATING MEDIUM:
 STEAM HEAT EXCHANGER
 1" SCHED. 40 FINNED TUBE PIPE
 WITH 2" SCHED. 40 HEADERS
 200 PSIG MAX. PRESSURE
4. SPILL CONTAINMENT: 55 GALLONS
5. MATERIALS:
 EXTERIOR: HRS, 14 GA. (.075")
 INTERIOR: HRS, 12 GA. (.105")
 FORMED CHANNEL GRATING
 INSULATION: 3" X 6# DENSITY MINERAL WOOL
 (ALL WALLS, FLOOR, CEILING AND DOOR)

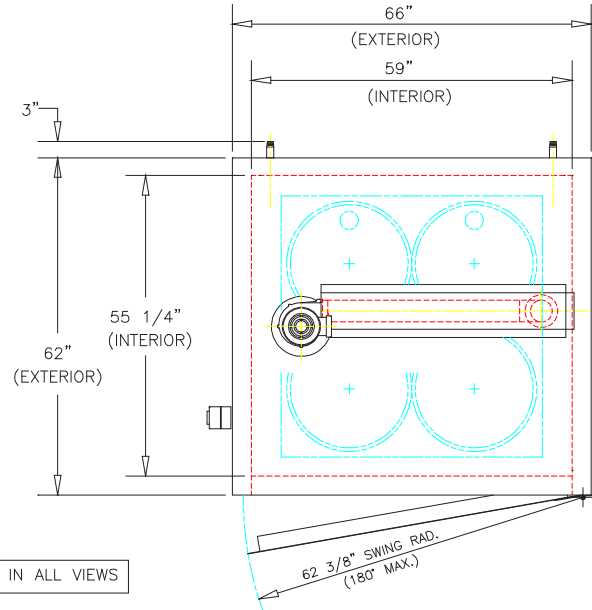

FOR CLARITY NOT ALL FEATURES SHOWN IN ALL VIEWS

OPTIONS
SELF-ACTING TEMPERATURE CONTROL
STEAM TRAP
VENT W/DAMPER
INTERIOR DOOR LATCH RELEASE
SPILL PAN DRAIN VALVE
CUSTOM FINISHES
OUTDOOR PACKAGE
ADDITIONAL HEAT EXCHANGERS
ADDITIONAL HEIGHTS
AIR RECIRCULATION BLOWER
ELECTRONIC CONTROL PACKAGE
FIVE YEAR WARRANTY

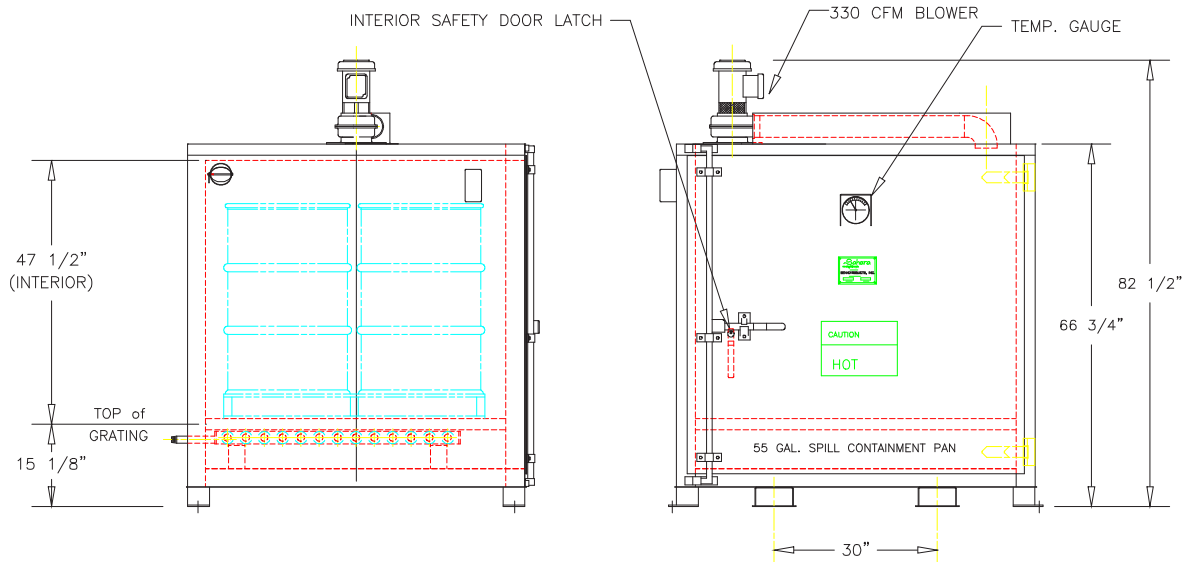

BENKO PRODUCTS
 ENGINEERED TO BE MORE

WARRANTY: All products manufactured by Benko Products, Inc. have a two (2) year warranty (unless otherwise specified) from the date of purchase against defects in workmanship or material. Any part or component, except items covered by warranties of other manufacturers, returned to the factory or service center freight prepaid by the owner, found upon examination by Benko Products, Inc. to be defective or the result of improper workmanship by the factory will be repaired or replaced without charge and returned to the owner freight prepaid by Benko Products, Inc. Any alterations of Benko Products, Inc. products void any warranty or liability on the part of Benko Products, Inc. Benko Products, Inc. does not guarantee product capacity if alterations are made.