



Manufactured by  
**BENKO PRODUCTS**  
ENGINEERED TO BE MORE

## Steam Hot Box Model S12

The Benko Products SAHARA HOT BOX drum heaters and ovens are recognized as the industry leader in 55-gallon drum heating equipment. Steam drum heaters are available with state-of-the-art digital controls with independent over-temperature protection. Units in a manifolded arrangement can be individually turned off when not heating, perfect for your drum storage and drum heater needs.



### Specifications

The Hot Box has many unique features:

- Rugged steel construction
- Portable; just pick-up with a forklift
- Built-in spill containment
- Zero-ground clearance available
- **2-year Manufacturer's warranty**

### Capacity

12 drums (55 gal.) or 3 totes  
12,000 lbs. total capacity

### Materials of Construction

All steel construction includes:

- 12 gauge interior walls and 14 gauge exterior walls
- Integrated framing and structural members ensure toughness
- 304 stainless steel construction available

### Dimensions

Interior dimensions:

172.25"W x 55.25"D x 47.75"H

Exterior dimensions:

179.25"W x 62"D x 68.25"H

### Insulation

3" thick, 6# density mineral wool

### Heating Medium

Steam, hot oil, or hot water

### Heat Exchanger

Finned tube heating coil rated for saturated steam up to 200 psig. Recirculating coil available for hot oil or hot water.

### Temperature Range

Room temperature to 350°F

### Spill Containment Pan

160 gallon capacity

### Finish

- Exterior finished with acrylic enamel
- Interior finished with heat resistant silver
- Stainless steel available

### Unit Weight

5,150 lbs.

### Installation

Shipped completely assembled.

Set in place and hook up power supply.

### Engineering

Custom engineered, computer designed units are available. Contact us for more information.

\* Class A ovens available for heating flammables.

Designed, Patented and  
Manufactured by:

**BENKO PRODUCTS**  
ENGINEERED TO BE MORE

Benko Products Inc. · 5350 Evergreen Pkwy · Sheffield Village, Ohio · 44054  
Phone (440) 934-2180 · Fax (440) 934-4052 · email: [info@benkoproducts.com](mailto:info@benkoproducts.com)  
[www.benkoproducts.com](http://www.benkoproducts.com)



Manufactured by  
**BENKO PRODUCTS**  
 ENGINEERED TO BE MORE

# Steam Hot Box

## Model S12

**NOTES:**

1. UNIT WEIGHT: 5150 Lbs. (AS SHOWN)
2. FINISH:  
 EXTERIOR: ACRYLIC ENAMEL  
 INTERIOR: ALUMINUM-BASED ENAMEL
3. HEATING MEDIUM:  
 STEAM HEAT EXCHANGER  
 1" SCHED. 40 FINNED TUBE PIPE  
 WITH 2" SCHED. 40 HEADERS  
 200 PSIG MAX. PRESSURE
4. SPILL CONTAINMENT: 160 GALLONS
5. MATERIALS:  
 EXTERIOR: HRS, 14 GA. (.075")  
 INTERIOR: HRS, 12 GA. (.105")  
 FORMED CHANNEL GRATING  
  
 INSULATION: 3" X 6# DENSITY MINERAL  
 WOOL (ALL WALLS, FLOOR,  
 CEILING AND DOORS)

OPTIONS
SELF-ACTING TEMPERATURE CONTROL
STEAM TRAP
VENT W/DAMPER
INTERIOR DOOR LATCH RELEASE
SPILL PAN DRAIN VALVE
CUSTOM FINISHES
OUTDOOR PACKAGE
ADDITIONAL HEAT EXCHANGERS
ADDITIONAL HEIGHTS
AIR RECIRCULATION BLOWER
ELECTRONIC CONTROL PACKAGE
FIVE YEAR WARRANTY

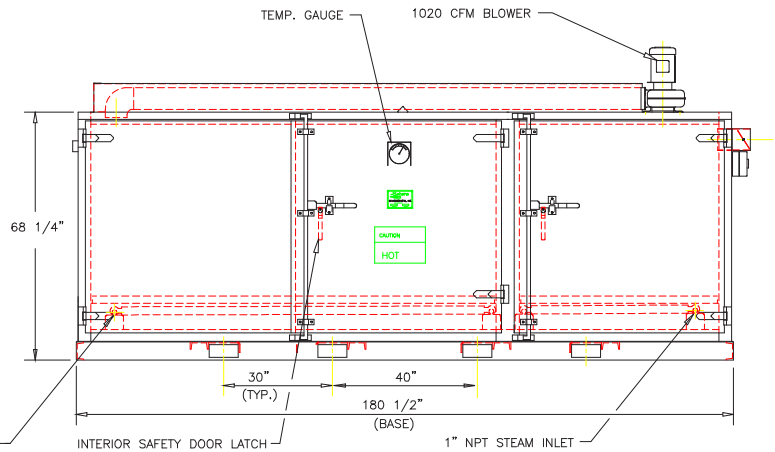
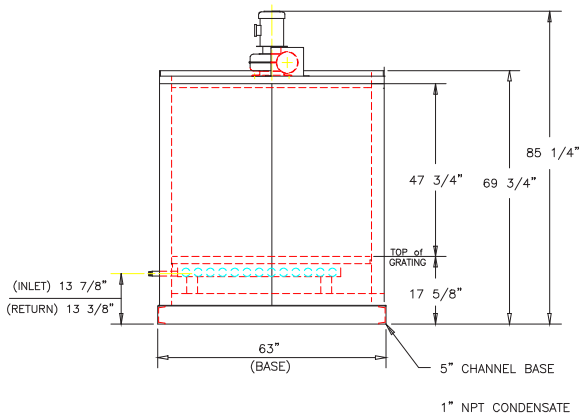
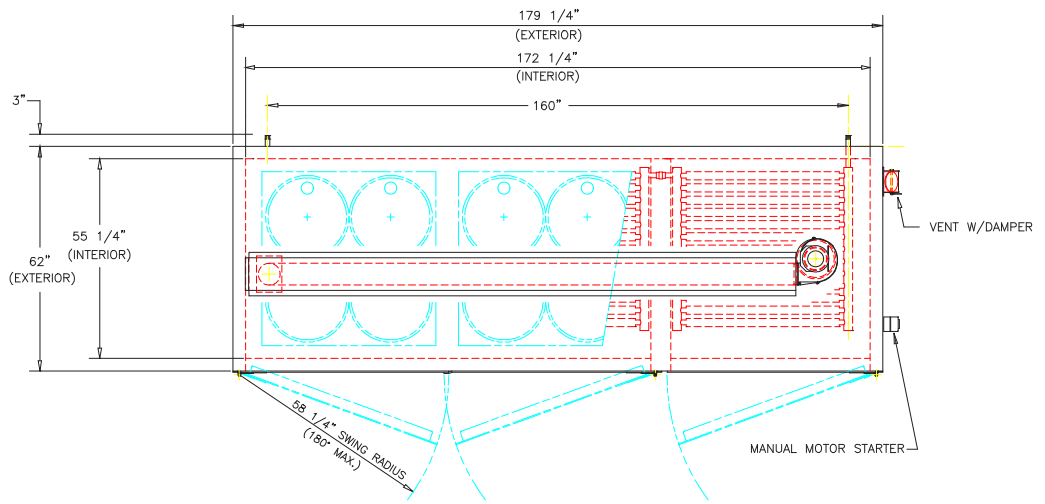

**BENKO PRODUCTS**  
 ENGINEERED TO BE MORE

**WARRANTY:** All products manufactured by Benko Products, Inc. have a two (2) year warranty (unless otherwise specified) from the date of purchase against defects in workmanship or material. Any part or component, except items covered by warranties of other manufacturers, returned to the factory or service center freight prepaid by the owner, found upon examination by Benko Products, Inc. to be defective or the result of improper workmanship by the factory will be repaired or replaced without charge and returned to the owner freight prepaid by Benko Products, Inc. Any alterations of Benko Products, Inc. products void any warranty or liability on the part of Benko Products, Inc. Benko Products, Inc. does not guarantee product capacity if alterations are made.