

Sahara

INDUSTRIAL OVENS

Electric Hot Box Model E12

The Benko Products SAHARA HOT BOX drum heaters and ovens are recognized as the industry leader in 55-gallon drum heating equipment. Electric drum heaters feature state-of-the-art digital controls with independent over-temperature protection. Low-watt density heaters assure years of trouble-free operation.



Specifications

The Hot Box has many unique features:

- Precise digital temperature control
- Portable; just pick-up with a forklift
- Built-in spill containment
- Zero-ground clearance available.
- **3-year Manufacturer's warranty**

Capacity

12 drums (55 gal.) or 3 totes
12,000 lbs total capacity

Materials of Construction

All steel construction includes:

- 12 gauge interior walls and 14 gauge exterior walls
- Integrated framing and structural members ensure toughness
- 304 stainless steel construction available

Dimensions

Interior dimensions:

172.25"W x 55.25"D x 49"H

Exterior dimensions:

179.25"W x 62"D x 84"H

Insulation

3" thick, 6# density mineral wool

Heating Medium

Electricity

Heat Capacity

- 20KW (optional kw ratings available)
- 240 or 480 volt, 3 phase (additional voltages available)
- Digital temperature controller with independent high temperature cut off

Temperature Range

Room temperature to 300°F

Spill Containment Pan

160 gallon capacity

Finish

- Exterior finished with acrylic enamel
- Interior finished with heat resistant silver
- Stainless steel available

Weight

4,875 lbs.

Installation

Shipped completely assembled.

Set in place and hook up power supply.

Air Circulation

2000 cfm air circulation blower with controls; 2 HP, TEFC

* Electric models not to be used to heat flammable or combustible materials.

* Electric models are not explosion proof rated and should not be used in hazardous locations.

* Class A ovens available for heating flammables.



Designed and
Manufactured by:

BENKO PRODUCTS
ENGINEERED TO BE MORE

Benko Products Inc. · 5350 Evergreen Pkwy · Sheffield Village, Ohio · 44054
Phone (440) 934-2180 · Fax (440) 934-4052 · email: sales@benkoproducts.com
www.benkoproducts.com



Also available with 'zero-ground clearance' design for pallet-jack loading / unloading.

Electric Hot Box

Model E12

NOTES:

1. UNIT WEIGHT: 4875 Lbs.
 2. FINISH:
EXTERIOR: ACRYLIC ENAMEL
INTERIOR: HIGH HEAT BLACK
 3. HEATING MEDIUM:
(8) 2.5KW ELECTRIC HEATING ELEMENTS
480V/3Ø/60HZ
 4. SPILL CONTAINMENT: 160 GALLONS
 5. MATERIALS:
EXTERIOR: HRS, 14 GA. (.075")
INTERIOR: HRS, 12 GA. (.105")
FORMED CHANNEL GRATING
- INSULATION: 3" X 6# DENSITY MINERAL WOOL (ALL WALLS, FLOOR, CEILING AND DOORS)

- OPTIONS**
- 2000 CFM BLOWER-TEFC
 - 480V - 2 HP - 3 PHASE
 - PROGRAMMABLE TIMER
 - DOOR/BLOWER INTERLOCK SWITCH
 - VENT W/DAMPER
 - INTERIOR DOOR LATCH RELEASE
 - OUTDOOR PACKAGE
 - CUSTOM FINISHES
 - ADDITIONAL HEIGHT
 - ADDITIONAL WATTAGE

SAHARA MODEL 20E12-CS

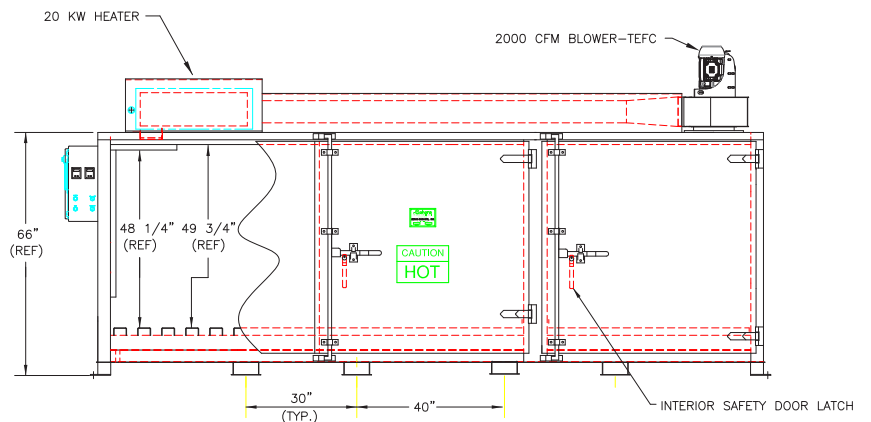
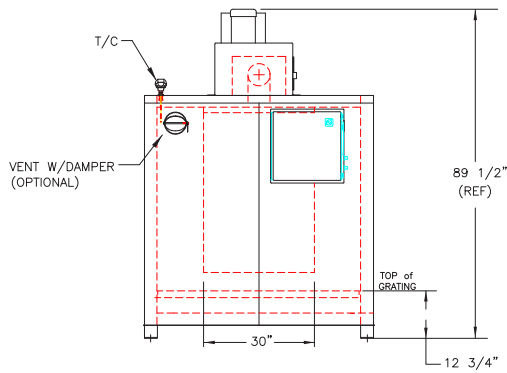
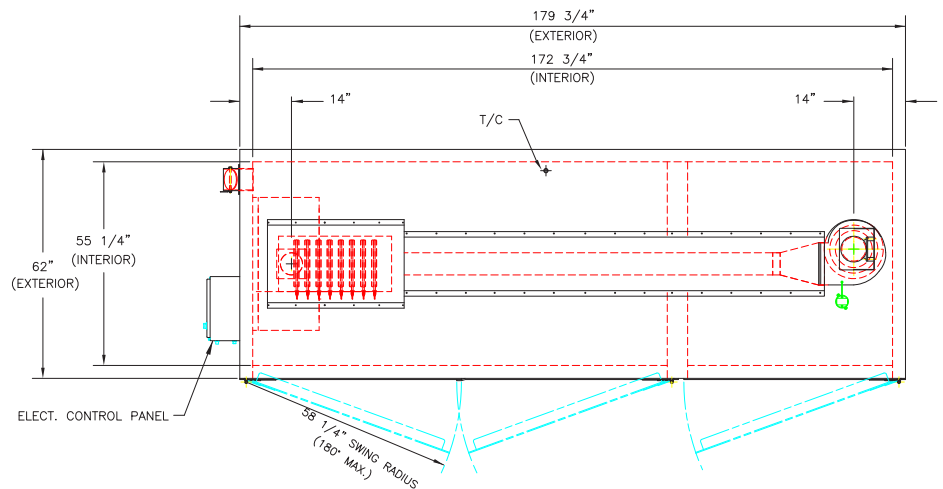

FOR CLARITY NOT ALL FEATURES SHOWN IN ALL VIEWS



WARRANTY: All products manufactured by Benko Products, Inc. have a three (3) year warranty (unless otherwise specified) from the date of shipment against defects in workmanship or material. Any part or component, except items covered by warranties of other manufacturers, returned to the factory or service center freight prepaid by the owner, found upon examination by Benko Products, Inc. to be defective or the result of improper workmanship by the factory will be repaired or replaced without charge and returned to the owner freight prepaid by Benko Products, Inc. Any alterations of Benko Products, Inc. products void any warranty or liability on the part of Benko Products, Inc. Benko Products, Inc. does not guarantee product capacity if alterations are made.