



HORIZONTAL LIFELINE SYSTEM DATA SHEET

Division of Benko Products, Inc.

PRODUCT DESCRIPTION

G-Raff Horizontal Lifeline Systems are designed to provide safe access and fall protection on the tops of hopper cars, tank cars and tank trucks.

SYSTEM FEATURES

Multi-Span, Sayfglida Horizontal Lifeline System. G-Raff Insta-Rack Platform and folding extension gangway. Rugged steel cable supports. Single or multiple car applications.

MATERIALS OF CONSTRUCTION

Insta-Rack Platform and Stairway:
All steel construction.
Sayfglida components:
Stainless steel.
Cable supports:
All steel construction.

FINISH

Standard gray primer.
Hot dipped galvanized available.
Top coat per customer specification available.

APPROXIMATE WEIGHTS

Insta-Rack Platform and Gangway 2,500 lbs.
Cable supports 2,200 lbs. each.

SAFETY

Meets OSHA requirements as interpreted.

INSTALLATION

Complete assembly instructions provided. Installation of the Sayfglida system will be provided by a Sayfglida technician.

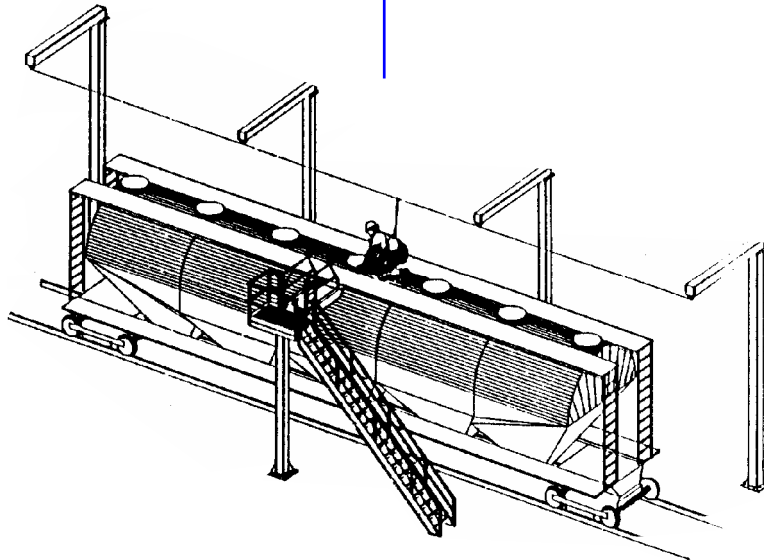

G-RAFF SYSTEMS

Division of Benko Products, Inc.

5350 Evergreen Pkwy, Sheffield Village, OH 44054

(440)238-4360 Fax(440)238-4363

www.g-raffsystems.com e-mail: dingram@g-raffsystems.com

This document was created with Win2PDF available at <http://www.win2pdf.com>.
The unregistered version of Win2PDF is for evaluation or non-commercial use only.
This page will not be added after purchasing Win2PDF.